

SAILFISH[®]

Demand the Difference







Fishing, Family, Fun

For over 25 years, Sailfish has provided the saltwater enthusiast with a full line-up of reliable, stylish, and user friendly boats capable of withstanding the rigors of the inshore and offshore environments.

DEMAND THE DIFFERENCE is more than just a slogan; it's a strategy to exceed customer's expectations. With a CSI rating always in the top 10 percent, and winner of the NMMA CSI Award 5 years in a row, customer satisfaction is a hallmark of Sailfish ownership.

At its core, Sailfish is a fishing boat – designed by anglers for anglers – loaded with more standard equipment for anglers than any other boat on the water. Multiple rod holders in front and rear, insulated fish boxes, and built-in tackle storage are just some of the fishing friendly features that you'll find on every Sailfish boat.

Still, anglers do not live by fishing alone, and for that reason a Sailfish is designed to be a hard-core tournament fishing boat one day and a versatile family fun boat the next day. With comfortable full bow seating, stow away tables, abundant storage space and a retractable ski tow bar, your Sailfish provides for an exciting family day on the water.

With a reputation for quality and a history of innovation, Sailfish continues to be one of the premier saltwater fishing boats on the market and the best overall value. When it comes to your boating investment, shouldn't you DEMAND THE DIFFERENCE?



Demand The Difference

Intelligent Ergonomic Design

The fact that Sailfish Boats seem to just “work” better is no accident. From the ergonomic layout of the helm and console to the deep gunwales and wide walkways from front to rear, every inch of every Sailfish model is planned and thought through for maximum utilization of available space. From strategic seat heights and raised footrests to strategically placed controls and instrumentation, everything is located to provide maximum ease of operation. That’s a “DIFFERENCE” you can feel every time you get on board.

Quality Construction – Built To Last!

Each Sailfish is quality built using only the best materials and proven manufacturing techniques – from start to finish there are no shortcuts taken in the manufacturing process. Kevlar® & carbon fiber reinforcements are added for durability, and the entire stringer system is foam-

filled for added safety. Many standard features – such as rod holders, live wells and tackle storage compartments are molded directly into the boat for greater durability and ease of use. Our exclusive raised-dot, non-skid surfaces make for easier cleaning and maintenance – without back-breaking scrubbing on your hands and knees. All these “DIFFERENCES” are starting to add up.

Unmatched Fit & Finish

It’s the little things that make the difference between a good boat and a great boat. All Sailfish boats are finished using the best available gelcoats, masterfully applied and polished to a bright shine. All hinges and deck lids are recessed into the mounting surface leaving nothing protruding to stub your toe or cut your feet when barefoot. Cup holders, storage compartment latches, light fixtures, instruments are securely installed and inspected. Our quality control is second to none; each Sailfish

boat is painstakingly examined for flaws and imperfections before it leaves the plant – this attention to detail is another “DIFFERENCE” that separates Sailfish from other boat builders.

There Is Simply No Safer Boat On The Water.

From the 220 to the 320, Sailfish models offer the greatest cockpit depth in the industry, keeping water out and people in. Sailfish boats also feature the largest recessed, self-bailing cockpit drains in their class, allowing the maximum amount of water to exit the deck providing an extra measure of safety. Our standard strategically placed bow rails allow users to lower their center of gravity and better maintain balance during pitch and yaw. An integral rear telescoping ladder is standard on all 22 to 32 foot Sailfish models – this allows for easy access outside the boat – now that’s a “DIFFERENCE” that can save a life.



100% Yamaha PowerMatched™ Components

All Sailfish boats are equipped standard with powerful, fuel-efficient Yamaha outboard motors and feature genuine Yamaha PowerMatched™ rigging components as standard equipment. On all models nineteen feet and up, this feature extends rigging

component warranties for a full three years. Compatibility means dependability – another Sailfish “DIFFERENCE”.

Sailfish Owners Are Raving Fans

Sailfish is the flagship brand of the Seminole Marine Group, a 26-year old, family owned boat building company with a reputation for quality and customer

service. Sailfish has grown to be one of the largest saltwater boat manufacturers in the nation by producing quality products and delivering excellent customer service. Sailfish owners are raving fans who understand the “DIFFERENCE” and plan for their next boat to be a Sailfish as well. Are you ready to join the Sailfish family?

Exclusive VDS Hull Design

Only Sailfish boats feature the exclusive Variable Deadrise Stepped Hull – that improves lift and stability giving Sailfish Boats a smooth ride for all day enjoyment.

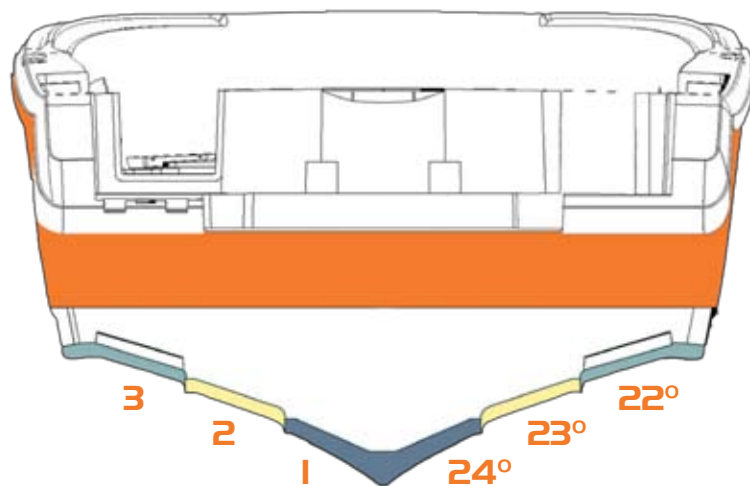

Three Hulls in One:

- The first hull cuts the water.
- The second hull combined with turn down strakes creates lift.
- The third hull creates stability.

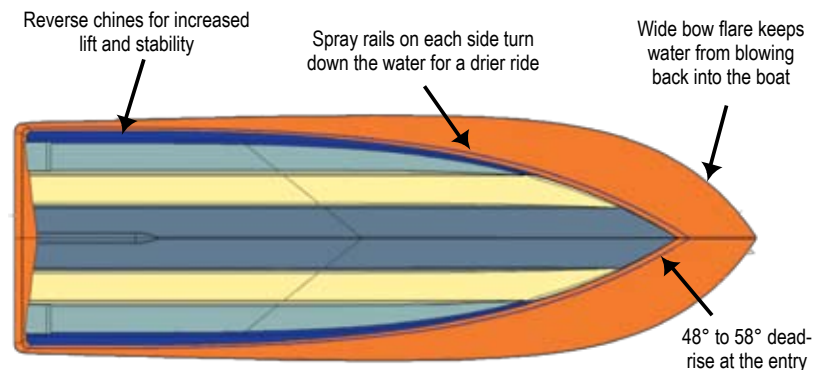

320 CC

SPECIFICATIONS

	U.S.	METRIC
LOA	31' 6"	9.6 M
Length Rigged	34'	10.4 M
Beam	10'	3.05 M
Fuel Capacity	300 Gal	1,135.62 L
Fresh Water	21 Gal	79 L
*Approx. Wet Weight	10,500 Lbs	4,763 kg
Cockpit Depth Rear	31"	78.74 Cm
Cockpit Depth Front	40"	102 Cm
Max. Hp w/Twins	700 Hp	522 kw
Draft - Hull	22"	55.88 cm
Deadrise (Variable)	22° - 24°	
Bridge Clearance w/T-Top	106"	2.69 Cm
Battery Capacity	3	
Person Capacity	Yacht Certified	
*With the Base Motor Package		



 SAILFISH

SAIFISH®

Serious offshore capability and dazzling style make the Sailfish 320CC the best performing big water boat we have brought to market. Our VDS hull design is the softest riding, driest hull in Sailfish history and the multiple deadrise, variable lift plane running surface, makes the 320CC both responsive, and extremely agile for a boat this size. But beyond the standards lies the real heart of Sailfish design, function, comfort, and practical ergonomics. Look over other brands in this size range, we think you'll agree that the Sailfish 320CC is the best of the best, and represents the clear choice in offshore fishing boats available at any price.

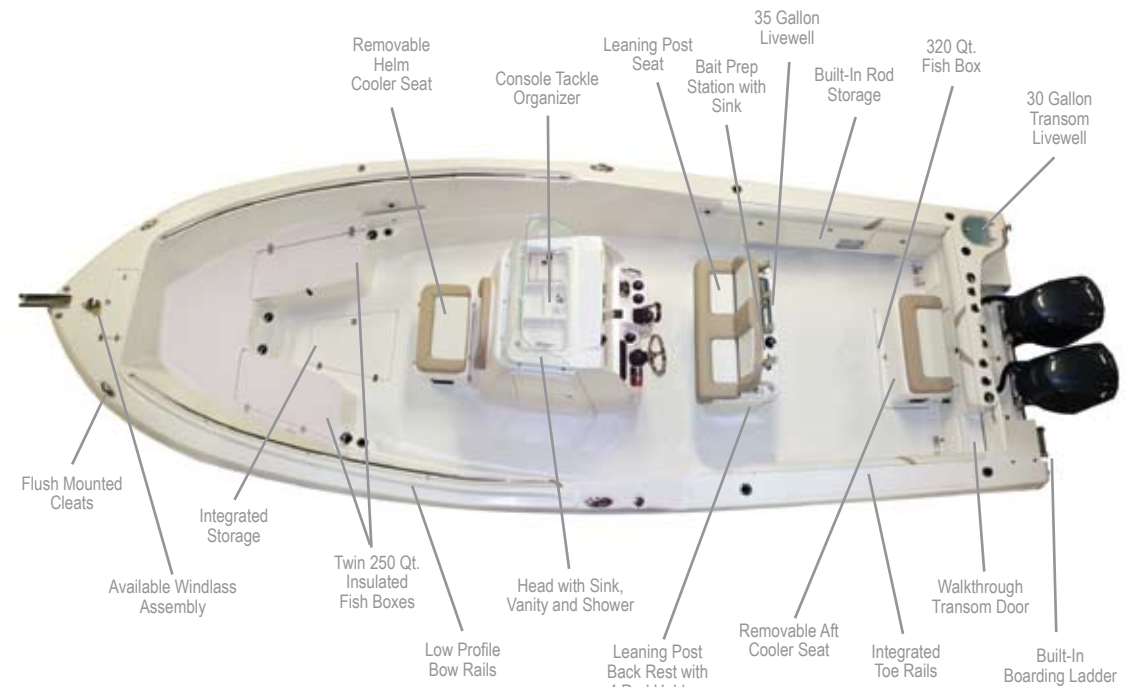

- VDS - Variable Drisrte Stepped Hull
- Dual Ram Steering
- Seating For 12 Or More
- 4-2" Recessed Deck Drains With Collector

- Raw Water Wash With High Speed Pickup
- Multi Position Cooler (150 Qt.) Seating
- Optional Bow Cushion Set
- Quad Ram High Performance Trim Tabs

- Full Deck Level Led Lighting
- Tilt Steering

320 EXP



SPECIFICATIONS

	U.S.	METRIC
LOA	31' 6"	9.6 m
Length Rigged	34'	10.4 m
Beam	10'	3.05 m
Fuel Capacity	300 Gal	1,135.62 L
Fresh Water	21 Gal	79.49 L
*Approx. Wet Weight	11,850 Lbs	5,375 kg
Cockpit Depth Rear	31"	78.74 cm
Cockpit Depth Front	40"	102 cm
Max. Hp W/Twins	700 Hp	522 kw
Draft - Hull	22"	55.88 cm
Deadrise (Variable)	22° - 24°	
Bridge Clearance w/T-Top	115"	2.921 m
Battery Capacity	3	
Person Capacity	Yacht Certified	
*With the Base Motor Package		

Optional Pilot House Package

SAIFISH®

Serious offshore capability, a fully appointed cabin with berths for 6 or more, and dazzling style, combine to make the Sailfish 320 Express the sport utility of the sea. Whether cruising to dinner, or fishing the gulf stream, this boat provides the lifestyle you've always dreamed about. Standard fishing amenities include 14 upright rod holders, 30 gallon live well with high speed pickup, 2 deluxe tackle stations, and much more. Cruising features include enclosed shower/ head, teak cabin sole, fold down bunks, aft berth, refrigerator, stove, microwave, shore power and hot water heater. Riding on the best performing hull design in the industry, the world is at your beck and call with the Sailfish 320 Express.

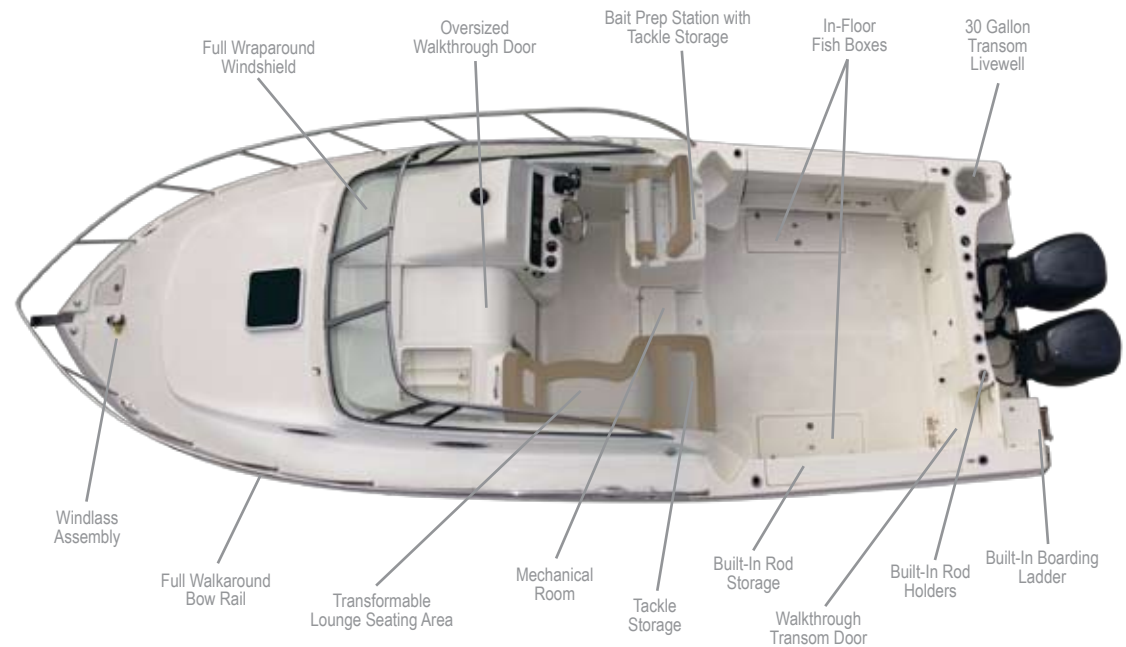

Optional Pilot House Package

- Standard Deluxe Hard Top
- Available Seating for 8 Or More
- Enclosed Stand-Up Shower & Head
- Multiple Hull Color Options

- Optional Air Conditioner
- Standard CD/Stereo System
- Standard Galley With Sink, Stove, Microwave & Refrigerator

- Standard High Performance Trim Tabs
- VDS - Variable Deadrise Stepped Hull



290 CC

SPECIFICATIONS

	U.S.	METRIC
LOA Hull Only	28' 6"	8.7 m
Length Rigged	30' 6"	9.3 m
Beam	9'	2.75 m
Fuel Capacity	240 Gal	908.5 L
Fresh Water	14 Gal	53 L
*Approx. Wet Weight	8,000 Lbs	3,629 kg
Cockpit Depth Front	40"	76.2 cm
Cockpit Depth Rear	30"	1.01 m
Max. Hp w/Twins	600 Hp	447.42 kw
Draft - Hull	21"	53.3 cm
Deadrise (Variable)	22° - 24°	
Battery Capacity	3	
Bridge Clearance	106"	2.7 m
Person Capacity	Yacht Certified	
*With the Base Motor Package		



The new 290CC has enormous offshore capabilities and a new sleek Sailfish look with dazzling style. With the proven VDS high performance hull design, this boat is one of the driest, softest riding 29 footers on the market today. Loaded with standard fishing amenities, including 16 rod holders, 35 gallon leaning post live well, 30 gallon transom live well with high speed pickup, dual fish boxes in the floor, rod storage and much more. The 290CC also boasts more available options to accommodate your everyday family needs as well as your tournament needs.

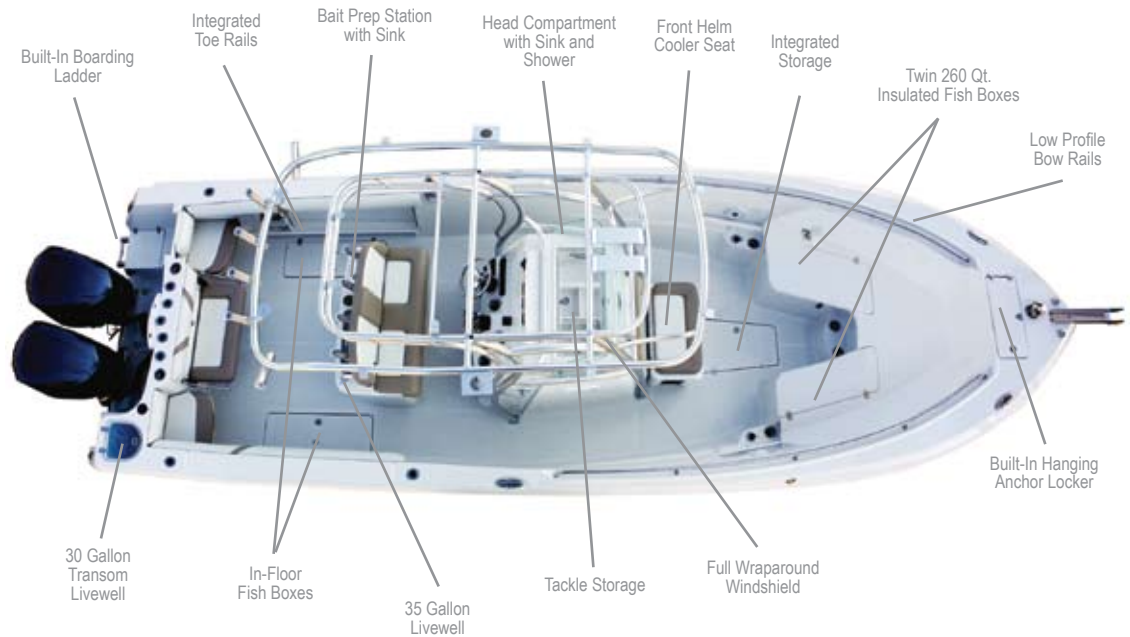

- VDS - Variable Deadrise Stepped Hull
- Optional Dual Ram Steering
- Seating for 12 or More

- Raw Water Wash with High Speed Pickup
- Recessed Deck Drains with Collector
- Optional Bow Cushion Set

- Multiple Hull Color Options
- High Performance Recessed Trim Tabs
- Optional Front Fishing Bolsters



270 WAC

SPECIFICATIONS

	U.S.	METRIC
LOA Hull Only	26' 2"	7.97 m
Length Rigged	28' 2"	8.55 m
Beam	9'	2.74 m
Fuel Capacity	200 Gal	757 L
Fresh Water	14 Gal	52 L
*Approx. Wet Weight	7,400 Lbs	3,357 kg
Cockpit Depth Rear	30"	76.2 cm
Cockpit Depth Front	32"	81.2 cm
Max. Hp W/Twins	500 Hp	450 kw
Draft - Hull	18"	45.72 cm
Deadrise (Multi Angle)	22° - 24°	
Bridge Clearance	107"	271.78 cm
Battery Capacity	3	
Person Capacity	Yacht Certified	
*With the Base Motor Package		





The 270WAC is designed to be the most accommodating and fishable walk around cuddy cabin on the market. The spacious cockpit includes standard livewell, fish box and rod holders galore. For extended overnights, the 270WAC cabin can be equipped with convenient amenities and includes a full stand up enclosed head and shower. Ample headroom, functional galley and a large v-berth makes for a comfortable stay. The 270WAC rides on the proven VDS Sailfish hull for the smoothest ride in offshore fishing. All in all, this Sailfish is an impressive combination of comfort and utility sure to please the serious angler or weekend boater.

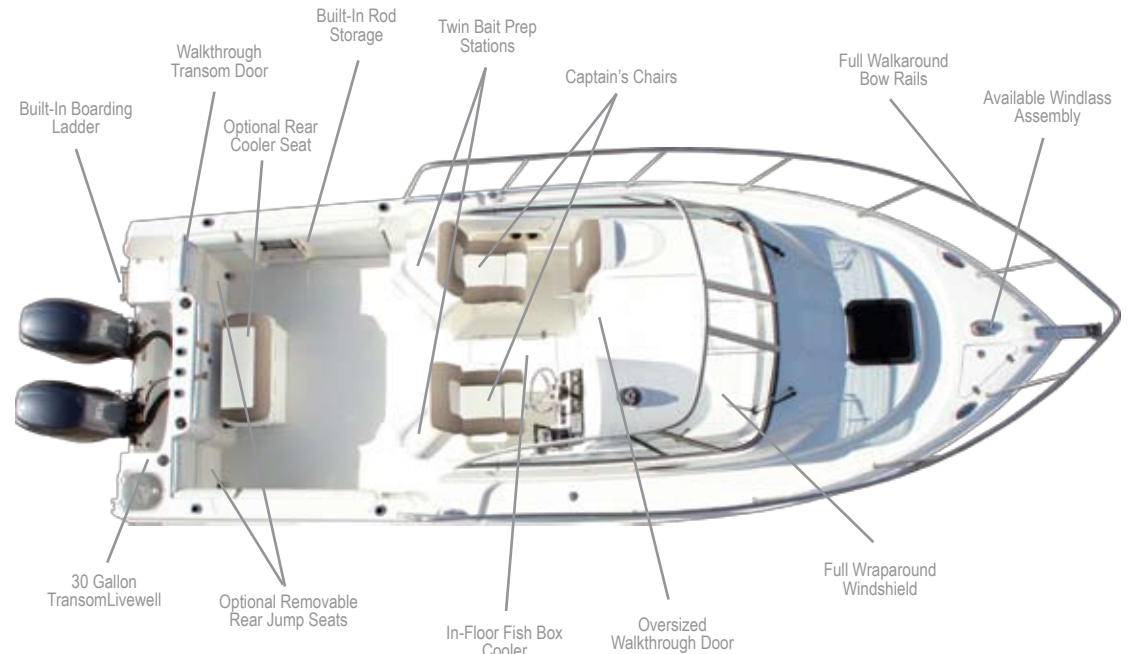

- Available Deluxe Hard Top
- Available Seating for 8 or More
- Enclosed Stand-Up Shower and Head Available with Optional Generator

- Optional Air Conditioner
- Optional Twin Tackle Organizers
- Standard CD/Stereo System

- Standard Galley with Sink, Stove and Ice Box (With Optional Microwave and Refrigerator)
- Standard High Performance Trim Tabs
- VDS - Variable Deadrise Stepped Hull



SAIFISH®



The 270CC is one of our most popular size fishing platforms. From the newly designed helm, to the expanded cockpit area, the 270CC is the largest and most user friendly boat in its class. Like all of the Sailfish boats, the 270CC incorporates the Sailfish VDS multiple deadrise, high performance hull design, making for one of the softest riding, best performing boats on the market. Loaded with standard equipment, not to mention the largest selection of options available, it's no wonder the Sailfish 270CC is the best selling boat in its class.

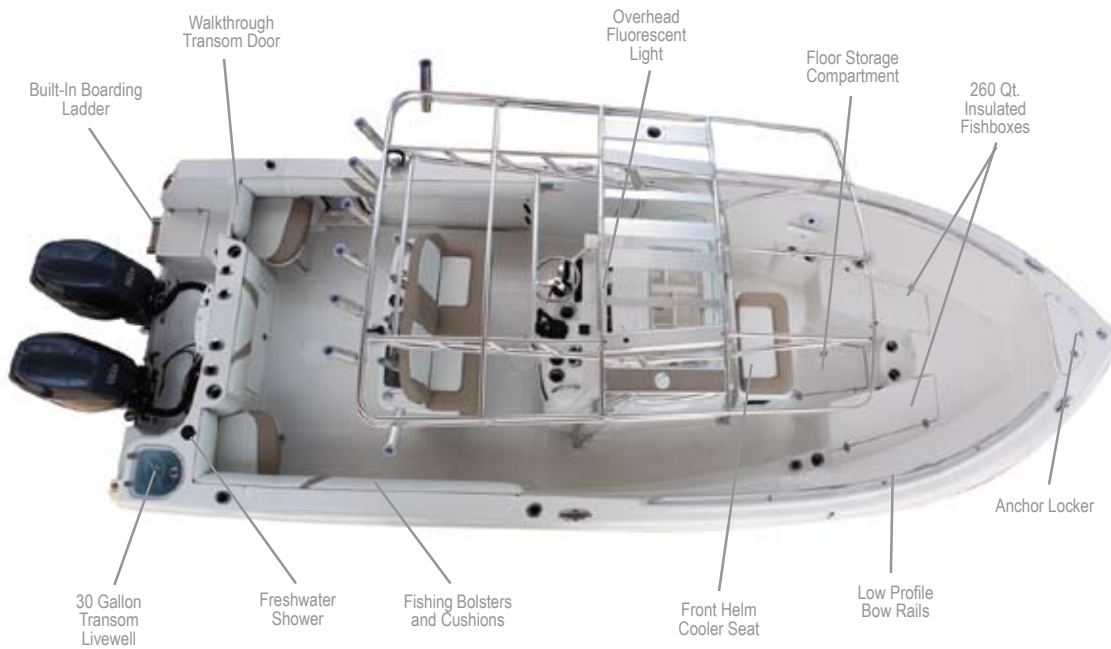

- Available Seating for 12 or More
- Easy Access Rigging Compartment
- Flush Mount Electronics Capability
- High Performance Trim Tabs
- Multiple Helm Seating Options
- Multiple Storage Compartments
- VDS - Variable Drisrise Stepped Hull

270 CC

SPECIFICATIONS

	U.S.	METRIC
LOA Hull Only	26' 2"	7.93 m
Length Rigged	28' 2"	8.54 m
Beam	9'	2.74 m
Fuel Capacity	200 Gal	756 L
Fresh Water	14 Gal	53 L
*Approx. Wet Weight	6,700 Lbs	3,039 kg
Cockpit Depth Rear	30"	76.12 cm
Cockpit Depth Front	40"	101.6 cm
Max. Hp w/Twins	500 Hp	450 kw
Draft - Hull	18"	45.72 cm
Deadrise (Variable)	22° - 24°	
Bridge Clearance w/T-Top	102"	259.08 cm
Battery Capacity	3	
Person Capacity	Yacht Certified	

**With the Base Motor Package*



240 WAC

SPECIFICATIONS

	U.S.	METRIC
LOA Hull Only	23' 6"	7.2 m
Length Rigged	25' 6"	7.8 m
Beam	9'	2.8 m
Fuel Cap	153 Gal	579 L
Fresh Water	14 Gal	53 L
*Approx. Wet Weight	6,350 Lbs	2,880 kg
Cockpit Depth Rear	29"	74 cm
Max Hp w/Twins	300 Hp	223 kw
Max Hp Single	300 Hp	223 kw
Draft	18"	46 cm
Deadrise (Multi-Angle)	22 - 24°	
Bridge Clearance w/Hard Top	105"	2.67 m
Battery Capacity	3	
Person Capacity	10	
<i>*With the Base Motor Package</i>		



SAILFISH®

The Sailfish 240WAC represents the most innovative cabin boat in its class. Developed on our world class VDS hull, renowned for superb performance and handling, the 240WAC is loaded with all of the top end amenities that Sailfish customers have come to expect. Not only is this the largest boat in the class, the new 240WAC's can be equipped as a competition quality fishing rig or optioned out to a luxury cruiser. Innovative design, maximized storage, and attention to detail make the Sailfish 240WAC the standard to which all must compare. Sailfish has built its reputation by delivering what the consumer demands. You too should "DEMAND THE DIFFERENCE", demand the new Sailfish 240WAC today.

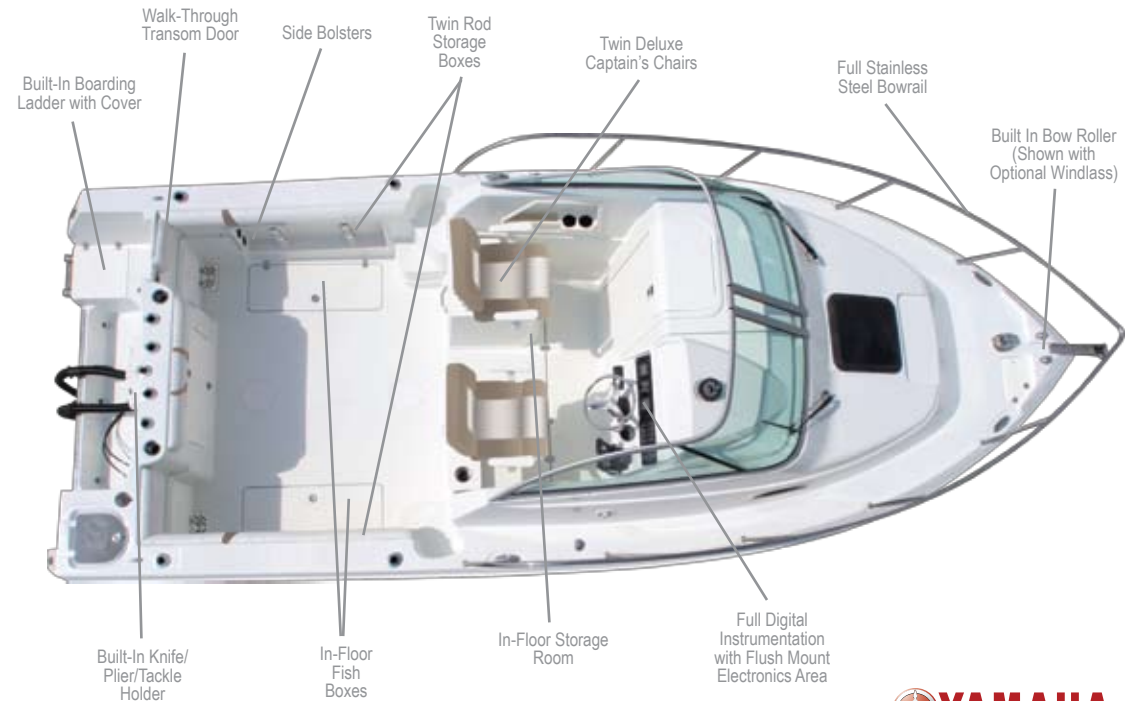
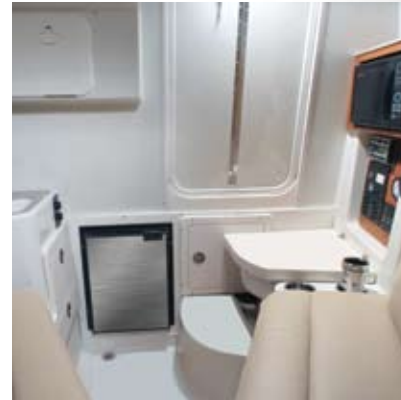

- 30 Gallon Transom Baitwell
- Optional Twin Fold-Down Bunk Beds In Cabin
- Full Galley
- Optional AC and Hot Water

- Twin Recessed Deck Drains with Collector Grates
- Twin Fold Down Foot Rests
- Yamaha Command Link Digital Gauge
- Optional Removable AFT Jump Seats

- 13 Available Rod Holders
- CD/Stereo and MP3 Jack
- VDS - Variable Deadrise Stepped Hull



SAILFISH®



You asked for it and we listened. This venerable Sailfish 24 footer is available with twin outboards or a single outboard. Increased cockpit space, newly redesigned helm, and enough standard equipment to make your mouth water have made the Sailfish 240CC one of the top-selling 24-foot center consoles on the market. Available in multiple eye-catching hull colors, and a huge variety of options and accessories, the 240CC can be delivered to your exact specifications.

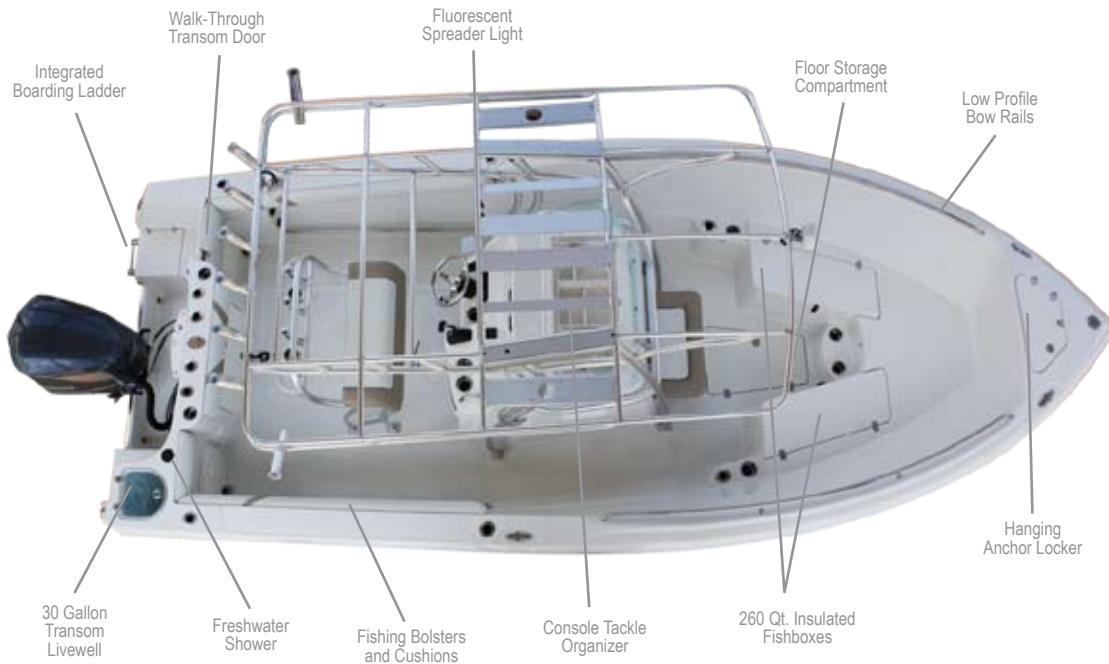

- Available Porta-Potti or Marine Head
- Available Seating for 10 or More
- VDS - Variable Deadrise Stepped Hull
- Easy Access Rigging Compartment

- Flush Mount Electronics Capability
- Multiple Hull Color Options
- Multiple Helm Seating Options
- Surface Mount Battery Switches

- Deepest Cockpit in Class
- Optional Dual Ram Steering
- Fully Framed Hull

240 CC

SPECIFICATIONS

	U.S.	METRIC
LOA	23' 6"	7.2 m
Length Rigged	25' 6"	7.8 m
Beam	9'	2.8 m
Fuel Cap	153 Gal	579 L
Fresh Water	14 Gal	53 L
*Approx. Wet Weight	5,600 Lbs	2,880 kg
Cockpit Depth Rear	30"	76.2 cm
Cockpit Depth Front	40"	101.6 cm
Max Hp w/Twins	300 Hp	223 kw
Max Hp Single	300 Hp	223 kw
Draft	18"	45.72 cm
Deadrise (Multi Angle)	22 - 24°	
Bridge Clearance w/Hard Top	102"	259.08 cm
Battery Capacity	3	
Person Capacity	10	



SAILEFISH®



If you want the feel of a center console with the comfort of a walk around cuddy, the Sailfish 220WAC is the boat for you and your family. A spacious cabin, equipped with overnight amenities, all the fishing features you could ever need, combined with proven Sailfish big water performance, put the 220WAC in a class of its own. With a large variety of options and accessories available, you can customize a 220WAC to fit your lifestyle.

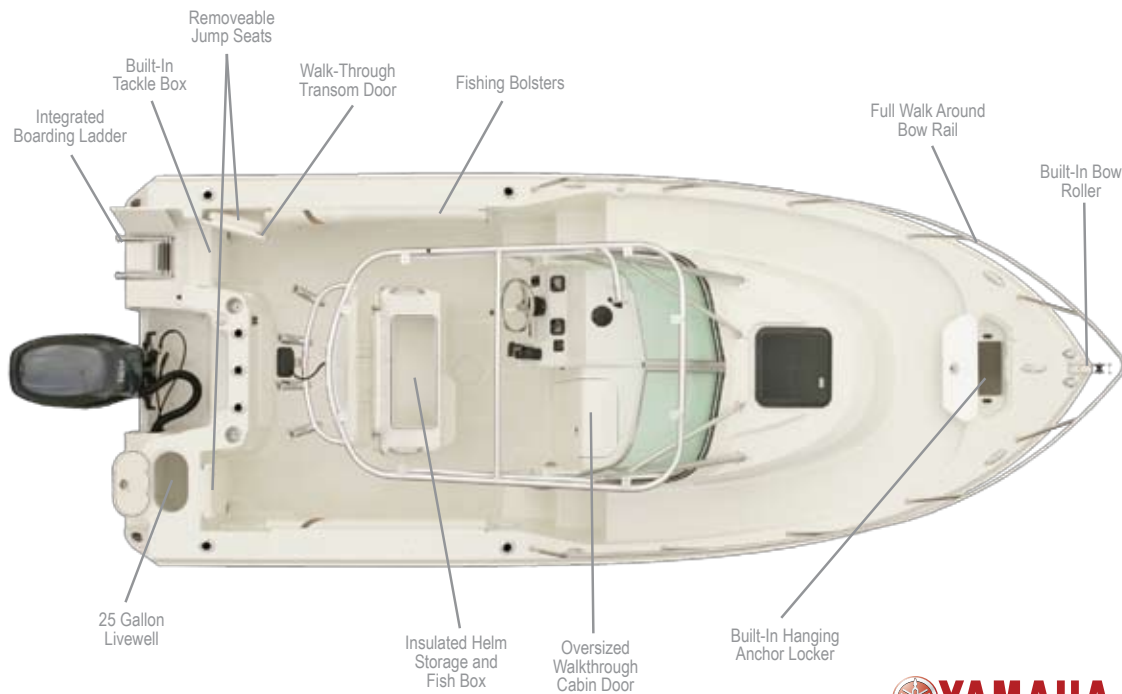

- Available Hard Top with Electronics Box
- Built-In 100 Quart Igloo Cooler Under Helm Seat
- Built-In AM/FM CD Stereo System
- Built-In Rod Storage (Accommodates 6 Rods)
- Full Galley with Fresh Water Sink, 25 qt. Cooler and Butane Stove
- Multiple Hull Color Options



220 WAC

SPECIFICATIONS

	U.S.	METRIC
LOA	21' 3"	6.48 m
Length Rigged	23' 6"	7.16 m
Beam	8' 6"	2.59 m
Fuel Capacity	95 Gal	359.61 L
Fresh Water	6 Gal	22 L
*Approx. Wet Weight	4,950 Lbs	2,245 kg
Cockpit Depth Rear	26"	66.04 cm
Max. Horsepower	250 Hp	187 kw
Draft - Hull	18"	45.72 cm
Deadrise (Multi Angle)	22° - 24°	
Bridge Clearance w/Hard Top	100"	254 cm
Person Capacity	8	

*With the Base Motor Package



220 CC

SPECIFICATIONS

	U.S.	METRIC
LOA Hull Only	21' 3"	6.48 m
Length Rigged	23' 3"	7.08 m
Beam	8' 6"	2.59 m
Fuel Capacity	95 Gal	359.61 L
*Approx. Wet Weight	4,450 Lbs	2,018 kg
Cockpit Depth Rear	26"	66.04 cm
Cockpit Depth Front	32"	81.28 cm
Max. Horsepower	250 Hp	186.43 kw
Draft - Hull	18"	45.72 cm
Deadrise (Multi Angle)	22° - 24°	
Bridge Clearance w/T-Top	100"	254 cm
Person Capacity	8	
<i>*With the Base Motor Package</i>		





The sailfish 220CC is one of the most popular 22 center consoles on the market. Talk to anyone who owns a 220CC and you'll find a true believer in the brand. An excellent ride in both smooth and rough seas, the 220CC sets the standard for all other boats in the class. Equipped for fishing or family fun, the 220CC is ready to go. Ample standard equipment along with multiple options and accessories allow you to have the boat of your dreams, in a package that's easily towed and as versatile as it gets. Test ride one today, you'll see what we mean.

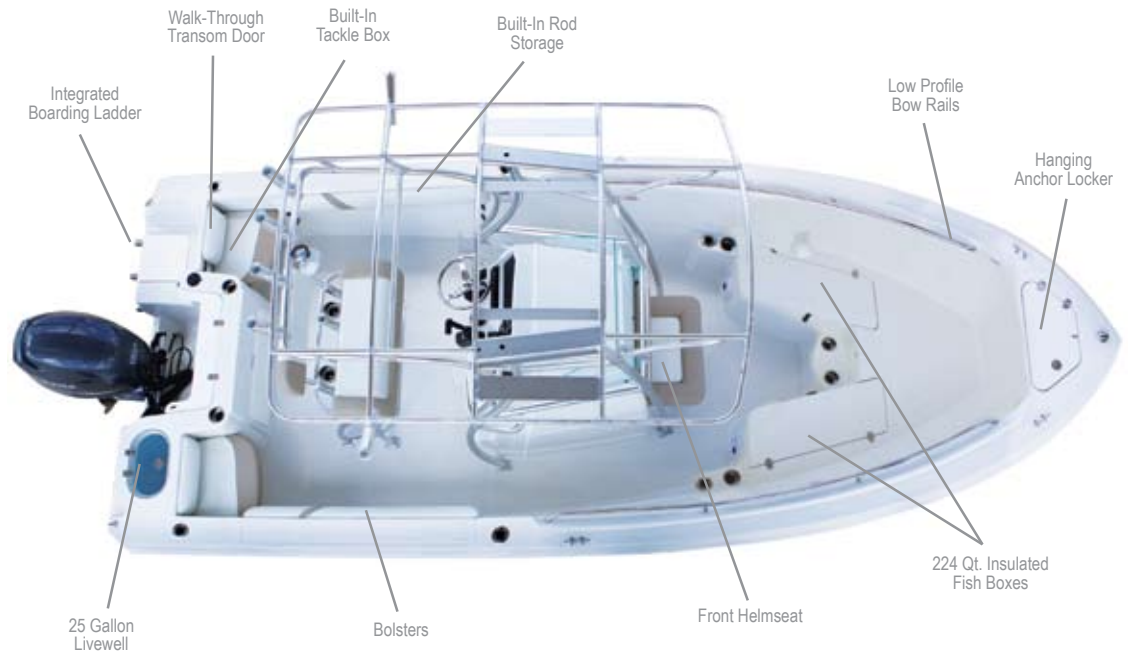

- Available Bow Cushion Package
- Available Electronics Box
- Available Fresh-Water Shower on Deck
- VDS - Variable Deadrise Stepped Hull
- Available Rear Jump Seats
- Multiple Helm Seating Options
- Multiple Hull Color Options

SAILFISH®



The Sailfish 208CC has delighted anglers and families alike for years. The versatile 208CC works as well offshore as it does on the flats. Classic design, functional standard equipment, and a variety of optional accessories allow you to customize your 208CC to your exact needs. Don't let the size fool you! Many expert anglers swear by the 208CC; it's a lot of boat in a very manageable size.

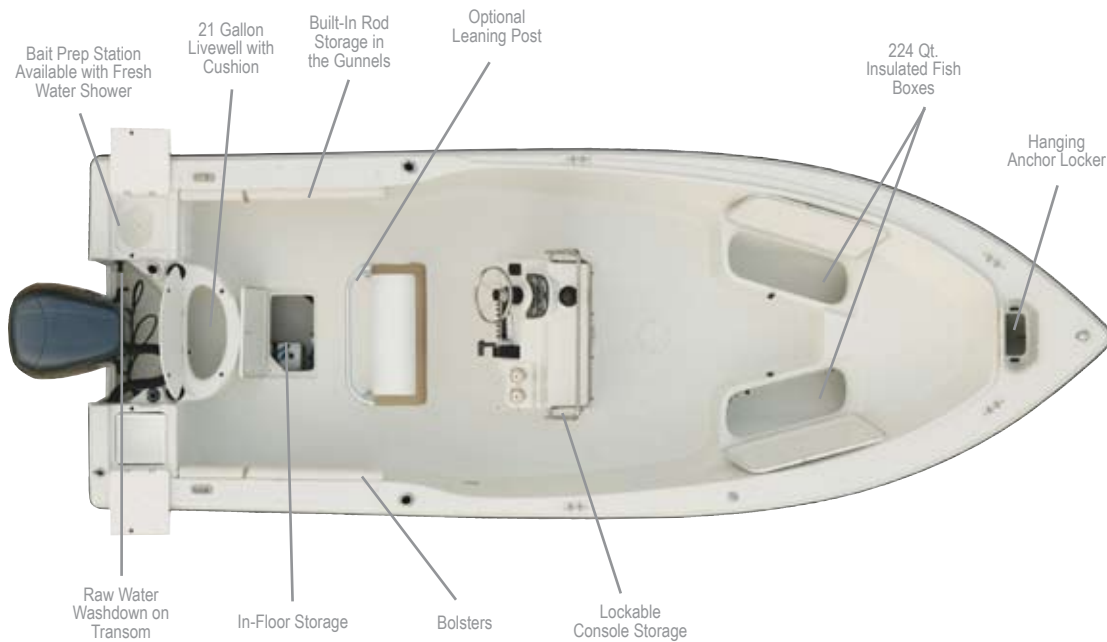

- Available Bow Cushion Package
- Available Front Helm Cooler Seat
- Available Porta-Potti Console w/Seat
- Multiple Helm Seating Options
- Multiple Hull Color Options
- VDS - Variable Deadrise Stepped Hull

208 CC

SPECIFICATIONS

	U.S.	METRIC
LOA Hull Only	20' 2"	6.15 m
Length Rigged	22' 2"	6.76 m
Beam	91"	2.31 m
Fuel Capacity	63 Gal	238.48 L
*Approx. Wet Weight	3,275 Lbs	1,690 kg
Max. Horsepower	200 Hp	149 kw
Draft	12"	53.34 cm
Deadrise (Variable)	19°-21°	
Bridge Clearance w/T-Top	98"	248.92 cm
Person Capacity	6	

**With the Base Motor Package*



2100 BB

SPECIFICATIONS

	U.S.	METRIC
LOA Hull Only	21'	6.40 m
Length Rigged	23'	7.01 m
Beam	8' 6"	2.59 m
Fuel Capacity	63 Gal	238.48 L
*Approx. Wet Weight	3,625 Lbs	1,644 kg
Max. Horsepower	200 Hp	149.14 kw
Draft - Hull	13"	33.02 cm
Deadrise	18°	
Bridge Clearance	65"	165.1 cm
Person Capacity	7	

**With the Base Motor Package*



SAILFISH®

Want the most versatile 21-foot bay boat on the market? The Sailfish 2100BB is for you. This boat is adaptable to both fresh and saltwater elements – inshore or offshore. The aggressive 18° deadrise hull means a soft ride in big water. The 2100BB is an angler's dream with features like large front and rear casting decks, 12 rod holders, multiple storage locations, and the capacity of three live wells. The 2100BB can be tailored to fit with multiple helm seating styles to meet and exceed your expectations.

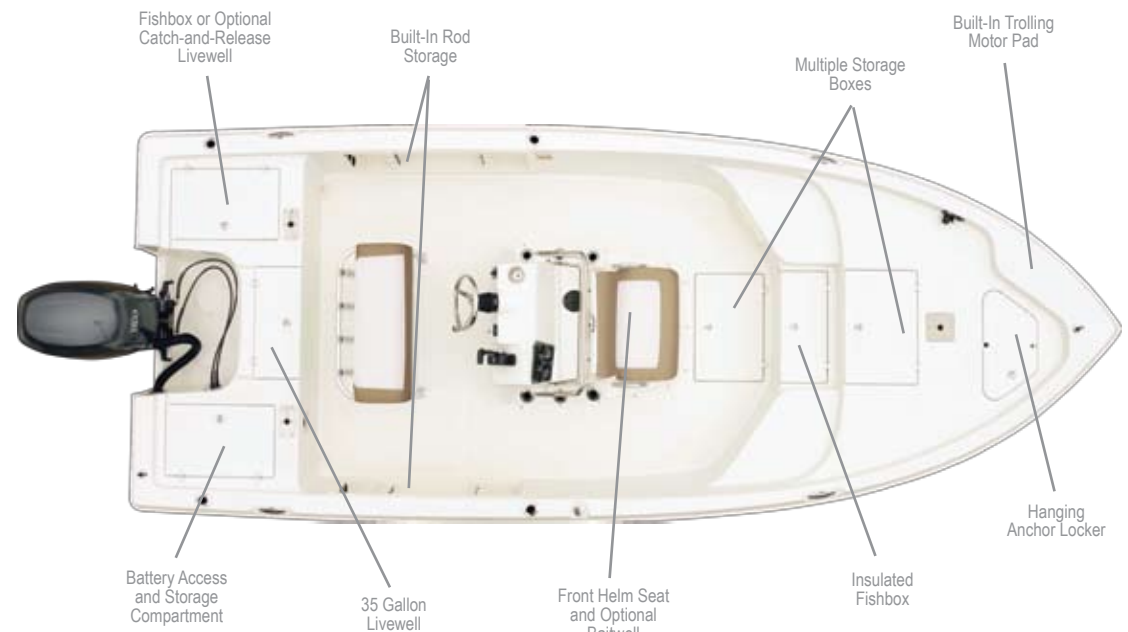

- 3 Available Livewells
- Available Built-In Battery Charger
- Available Front and Rear Jump Seat Cushions
- Available Trolling Motor and Plug with Tilt Switch
- Built-In Tackle Box (Second Tackle Box Optional)
- Multiple Helm Seating Options
- Multiple Hull Color Options

1900 BB

SPECIFICATIONS

	U.S.	METRIC
LOA Hull Only	19'	5.79 m
Length Rigged	21'	6.40 m
Beam	8' 6"	2.59 m
Fuel Capacity	52 Gal	197 L
*Approx. Wet Weight	2,750 Lbs	1,248 kg
Max. Horsepower	150 Hp	112 kw
Draft - Hull	13"	33.02 cm
Deadrise	18°	
Bridge Clearance	65"	165.1 cm
Person Capacity	5	

**With the Base Motor Package*



SAILEFISH®

The Sailfish 1900BB redefines the multipurpose bay boat. An aggressive 18° deadrise hull with 21" deep sides, standard 16-gallon bait well, optional catch and release live well, and abundant storage means you're ready for a full day fishing trip. The 1900BB is, by far, the most versatile boat in its class with seating capacity for 5 and easy access built-in boarding ladder. It doesn't matter if you're a weekend warrior or a professional angler, at the lake or in the bay, inshore or offshore the 1900BB gets the job done.

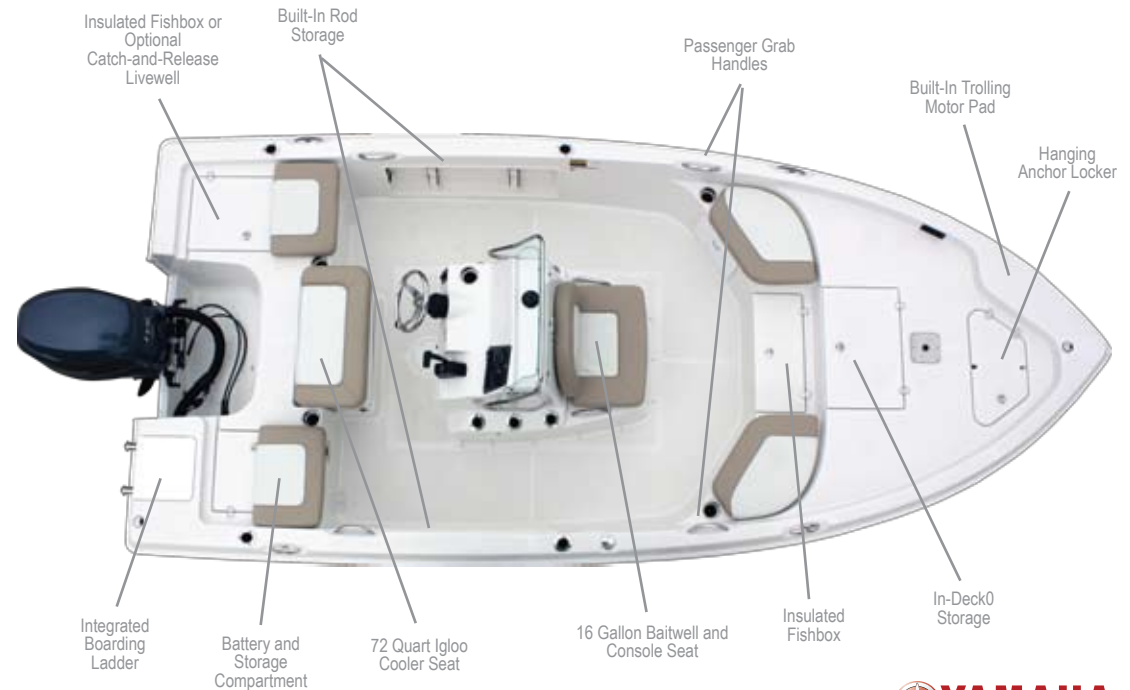
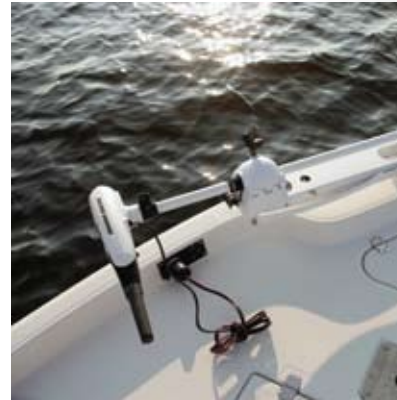

- Available Built-In Battery Charger
- Available Front and Rear Jump Seat Cushions
- Available Trolling Motor and Plug with Tilt Switch
- Built-In Tackle Box (Second Tackle Box Optional)
- Multiple Hull Color Options

Get Your Sailfish Just The Way You Want It!

Each Sailfish boat comes with an impressive array of standard features, but you can add from our menu of options and special packages to build your Sailfish just the way you want it.

Either choose from our menu of individual options, or take special discounts on one of our optional packages designed to make your Sailfish work for the way you're planning to use it.



Features & Options

	320 CC	320 EXP	290 CC	270 WAC	270 CC	240 WAC	240 CC	220 WAC	220 CC	208 CC	2100 BAY	1900 BAY
ELECTRICAL												
12 Volt DC Accessory Plug	•	•	•	•	•	•	•	•	•	•	•	•
Accessory Switch Panel w/Circuit Breakers	•	•	•	•	•	•	•	•	•	•	•	•
Battery Switch 1 or 2	2	2	2	2	2	2	2	1/D	1/D	1/D	1/D	1/D
Built-in Battery Charger	OPT	•	OPT	OPT	OPT	OPT	OPT	OPT	OPT	OPT	OPT	OPT
Cockpit Courtesy LED Lights	•	•	•	•	•	•	•	•	•	•	•	•
Compass	•	•	•	•	•	•	•	•	•	•	OPT	OPT
Electric Horn	•	•	•	•	•	•	•	•	•	•	•	•
Engine(s) Emergency Shut-Off Switch	•	•	•	•	•	•	•	•	•	•	•	•
Full Instrumentation With Yamaha Digital Gauges	N/A	N/A	N/A	N/A	N/A	N/A	N/A	N/A	N/A	•	•	•
Full Instrumentation With Yamaha Command Link Gauges	•	•	•	•	•	•	•	•	•	•	•	•
Stereo AM/FM	OPT	•	OPT	•	OPT	OPT	OPT	•	OPT	OPT	OPT	OPT
Stereo AM/FM/CD Player W/ Satellite Radio Receiver	OPT	OPT	OPT	OPT	OPT	OPT	OPT	OPT	OPT	OPT	OPT	OPT
Remote Control for Stereo AM/FM/CD Player	OPT	•	OPT	•	OPT	OPT	OPT	OPT	OPT	OPT	OPT	OPT
PLUMBING												
Automatic Bilge Pump	3/STD	3/STD	2/STD	2/STD	2/STD	2/STD	2/STD	•	•	•	•	•
Automatic Bilge Pump Additional	•	•	OPT	OPT	OPT	OPT	OPT	OPT	OPT	N/A	N/A	N/A
Bronze Garboard Drain Plug	•	•	•	•	•	•	•	•	•	•	•	•
Freshwater Shower	3	3	3	3	2	2	2	2	OPT	OPT	N/A	N/A
10 Micron Yamaha Fuel Filter/Water Separator	•	•	•	•	•	•	•	•	•	•	•	•
High Speed Livewell Pickup	•	•	•	•	•	•	•	•	•	•	•	•
Marine Head With Holding Tank & Overboard Discharge	OPT	•	OPT	OPT	OPT	OPT	OPT	N/A	OPT	N/A	N/A	N/A
Portable Marine Head	OPT	N/A	OPT	•	OPT	OPT	OPT	•	OPT	OPT	N/A	N/A
Raw Water Washdown	•	•	•	•	•	•	•	•	•	•	•	•
Self Bailing Cockpit	•	•	•	•	•	•	•	•	•	•	•	•
HARDWARE												
Marine Grade Hardware - Stainless Steel	•	•	•	•	•	•	•	•	•	•	•	•
Bow Anchor Roller	•	•	OPT	•	OPT	•	OPT	•	OPT	N/A	N/A	N/A
Engraved Transom Plate	•	•	•	•	•	•	•	•	•	•	•	•
Flush Mounted Bow Light	N/A	N/A	OPT	N/A	OPT	N/A	OPT	N/A	OPT	OPT	N/A	N/A
Flush Mounted Cleats	•	•	OPT	•	OPT	OPT	OPT	OPT	OPT	OPT	OPT	OPT
Flush Mounted Hinges & Deck Plates	•	•	•	•	•	•	•	•	•	•	•	•
Heavy Duty Rub Rail	N/A	N/A	•	N/A	•	•	•	•	•	•	•	•
Heavy Duty Stainless Steel Rub Rail	•	•	OPT	•	OPT	OPT	OPT	OPT	OPT	OPT	OPT	OPT
Heavy Duty Stainless Steel Bow & Stern Eyes	•	•	•	•	•	•	•	•	•	•	•	•
Ski Tow Bar Retractable	N/A	N/A	N/A	OPT	OPT	OPT	OPT	OPT	OPT	N/A	N/A	N/A
Stainless Full Bow Rail	N/A	•	OPT	•	OPT	•	OPT	•	OPT	OPT	N/A	N/A
Stainless Split Low Profile Bow Rail	•	N/A	•	N/A	•	N/A	•	N/A	•	OPT	N/A	N/A
Stainless Steel & Bronze Thru Hull Fittings	•	•	•	•	•	•	•	•	•	•	•	•
Stainless Steel Propeller(s)	•	•	•	•	•	•	•	•	•	•	•	•
Stainless Steel Rod Holders	12/STD	10/STD	7/STD	6/STD	6/STD	5/STD	6/STD	4/STD	4/STD	4/STD	8/STD	8/STD
Stainless Steel Rod Holders Additional Pair	OPT	OPT	OPT	OPT	OPT	OPT	OPT	OPT	OPT	OPT	OPT	OPT
Total Standard Rod Holders	30	19	17	16	12	9	12	10	12	8	14	14
SEATING												
Aft Seating	OPT	OPT	OPT	OPT	OPT	OPT	OPT	OPT	OPT	•	OPT	OPT
Baitwell Cushion	N/A	N/A	N/A	N/A	N/A	N/A	N/A	N/A	N/A	•	STD/OPT	•
Bow Cushions	OPT	N/A	OPT	N/A	OPT	N/A	OPT	N/A	OPT	•	N/A	N/A
Bow Cushion Back Rest Bolsters	OPT	N/A	OPT	N/A	OPT	N/A	OPT	N/A	OPT	N/A	N/A	N/A
Captains Chairs w/Removable Cushions	N/A	1	N/A	2	2	2	2	OPT	2	2	2	N/A
Captains Chair Foot Rest	N/A	•	N/A	•	OPT	•	OPT	•	OPT	OPT	OPT	N/A
Cockpit Table (Removable)	OPT	N/A	OPT	N/A	OPT	N/A	OPT	N/A	OPT	N/A	N/A	N/A
Console Seat/Front	•	N/A	•	N/A	•	N/A	•	N/A	•	•	•	•
Fishing Seat and Pedestal Pole Bow Mounted	N/A	N/A	N/A	N/A	N/A	N/A	N/A	N/A	OPT	OPT	OPT	OPT
Fishing Seat and Pedestal Pole Rear Mounted	N/A	N/A	N/A	N/A	N/A	N/A	N/A	N/A	N/A	N/A	OPT	OPT
L/P Alum. W/Built-in Back Rest & Rod Holders	OPT	N/A	OPT	N/A	OPT	N/A	OPT	N/A	OPT	N/A	OPT	N/A
L/P DLX. W/ 4 Rod Holders (Aluminum)	OPT	N/A	OPT	N/A	OPT	N/A	OPT	N/A	OPT	OPT	OPT	N/A
L/P Back Rest For Deluxe Aluminum Post	OPT	N/A	OPT	N/A	OPT	N/A	OPT	N/A	OPT	OPT	OPT	N/A
L/P DLX. W/Cooler & Premium Capt. Seats	OPT	N/A	OPT	N/A	OPT	N/A	OPT	N/A	N/A	N/A	N/A	N/A
Deluxe Leaning Post W/35 Gallon Livewell W/Backrest	•	N/A	•	N/A	OPT	N/A	N/A	N/A	N/A	N/A	N/A	N/A
L/P DLX. Fiberglass W/Fish Box & 94 QT Cooler	N/A	N/A	N/A	N/A	N/A	N/A	OPT	•	OPT	N/A	N/A	N/A
L/P DLX. Fiberglass W/Captain Chairs & Tackle Storage	OPT	N/A	OPT	N/A	OPT	N/A	OPT	N/A	N/A	N/A	N/A	N/A
Passenger Side Lounge Seating	N/A	•	N/A	OPT	N/A	N/A	N/A	N/A	N/A	N/A	N/A	N/A

Features & Options

	320 CC	320 EXP	290 CC	270 WAC	270 CC	240 WAC	240 CC	220 WAC	220 CC	208 CC	2100 BAY	1900 BAY
STORAGE												
Anchor Locker	•	•	•	•	•	•	•	•	•	•	•	•
Battery Compartment	•	•	•	•	•	•	•	•	•	•	•	•
Cooler (25, 75, or 120 Qt.)	75/STD	OPT	75/STD	OPT	75/STD	OPT	25/STD	2-25/100	OPT	OPT	OPT	72/STD
Deluxe Walk In Console / Lockable In Console Storage (Lockable)	•	N/A	•	N/A	•	N/A	•	N/A	•	N/A	N/A	N/A
Insulated -Fish Box / Storage	4	1	4	1	2	2	2	1	2	2	1	1
Recessed Cup Holders	•	•	•	•	•	•	•	•	•	•	•	•
Recessed Rod Storage	•	•	•	•	•	•	•	•	•	•	•	•
Tackle storage	•	•	•	•	•	•	•	•	•	•	•	•
Recessed Tackle Box Additional One	N/A	N/A	N/A	OPT	OPT	OPT	OPT	N/A	OPT	N/A	OPT	OPT
Recessed Top Mounted Console Tackle Organizer	•	•	•	N/A	OPT	N/A	OPT	N/A	OPT	N/A	N/A	N/A
FISHING												
Bait Prep Station	•	•	•	•	OPT	•	OPT	•	•	•	N/A	N/A
Baitwell Standard / Aerated In Gallons	35/30	30	35 / 30	30	30	30	30	25	25	21	35	16
Cockpit Bolsters	•	•	•	•	•	•	•	•	•	•	•	•
DLX. T-Top With LED Spreader Light & Rod Holders	•	N/A	OPT	N/A	OPT	N/A	OPT	N/A	OPT	OPT	OPT	OPT
DLX. Hard Top W/LED Spreader Light, Electronic Box & Rod Holders	OPT	•	OPT	•	OPT	OPT	N/A	OPT	N/A	N/A	N/A	N/A
Light Weight Hard Top Upgrade to DLX T-Top W/LED Lights	OPT	N/A	OPT	N/A	OPT	N/A	OPT	N/A	OPT	N/A	N/A	N/A
PFD Storage on Optional DLX. T-Top & Hard Tops	•	•	•	•	•	•	•	•	•	•	•	•
Pilot House Upgrade	OPT	OPT	OPT	OPT	OPT	OPT	OPT	N/A	N/A	N/A	N/A	N/A
Front & Side Curtains & Spray Curtains	OPT	OPT	OPT	OPT	OPT	OPT	OPT	OPT	OPT	OPT	OPT	OPT
Electronics Box (For Optional T-Top Only)	OPT	N/A	OPT	N/A	OPT	N/A	OPT	N/A	OPT	OPT	OPT	OPT
Fish Finder / GPS / Garmin Electronics	OPT	OPT	OPT	OPT	OPT	OPT	OPT	OPT	OPT	OPT	OPT	OPT
Inset Toe Hold Rail	•	•	•	•	•	N/A	•	N/A	N/A	N/A	N/A	N/A
Outriggers For T-Top & Hard Tops Only/ N/A on Pilot House Tops	OPT	OPT	OPT	OPT	OPT	OPT	OPT	OPT	OPT	OPT	N/A	N/A
Splashwell Tool Holder & Raw Water Washdown Hose Holder	N/A	N/A	•	•	•	•	•	N/A	N/A	N/A	N/A	N/A
Poling Platform	N/A	N/A	N/A	N/A	N/A	N/A	N/A	N/A	N/A	N/A	OPT	OPT
Powder Coated Hardware	OPT	OPT	OPT	OPT	OPT	OPT	OPT	OPT	OPT	OPT	OPT	OPT
Power Pole XL® (8')	N/A	N/A	N/A	N/A	N/A	N/A	N/A	N/A	N/A	OPT	OPT	OPT
Release Livewell / Pro Red Fish Tournament Pack	N/A	N/A	N/A	N/A	N/A	N/A	N/A	N/A	N/A	N/A	OPT	OPT
Trolling Motor	N/A	N/A	N/A	N/A	N/A	N/A	N/A	N/A	N/A	OPT	OPT	OPT
Trolling Motor Plug w/Trim	N/A	N/A	N/A	N/A	N/A	N/A	N/A	N/A	N/A	OPT	OPT	OPT
BOAT												
Bimini Top With Boot	N/A	N/A	N/A	OPT	OPT	OPT	OPT	OPT	OPT	OPT	OPT	OPT
Carbon Fiber Reinforced Deck	•	•	•	•	•	•	•	•	•	•	•	•
Closed Cell Foam Flotation	•	•	•	•	•	•	•	•	•	•	•	•
Colored Hull	•	•	OPT	•	OPT	OPT	OPT	OPT	OPT	OPT	OPT	OPT
Two Tone Colored Hulls	OPT	OPT	OPT	OPT	OPT	OPT	OPT	OPT	OPT	OPT	OPT	OPT
Boarding Ladder / Swim Platform	•	•	•	•	•	•	•	•	•	•	•	•
KEVLAR® Reinforced Hull	•	•	•	•	•	•	•	•	•	•	•	•
SailTech Composite Transom	•	•	•	•	•	•	•	•	•	•	•	•
SailTech Foam Filled Fiberglass Stringer System	•	•	•	•	•	•	•	•	•	•	•	•
Stainless Commander Steering Wheel (Hyd. Only)	•	•	•	•	•	•	•	•	•	•	•	•
Hydraulic Steering	•	•	•	•	•	•	•	•	•	•	•	•
Hydraulic Steering With Tilt Wheel	•	•	OPT	OPT	OPT	OPT	OPT	OPT	OPT	OPT	OPT	OPT
Power Assisted Hydraulic Steering	OPT	OPT	OPT	OPT	OPT	OPT	OPT	OPT	OPT	OPT	OPT	OPT
Transom Sink	N/A	N/A	N/A	N/A	N/A	N/A	N/A	N/A	N/A	N/A	N/A	N/A
Trim Tabs / High Performance / Heavy Duty	HP/HD	HP/HD	HP	HP	HP	N/A	N/A	N/A	N/A	N/A	N/A	N/A
Trim Tabs With Indicator Switch	•	•	OPT	OPT	OPT	OPT	OPT	OPT	OPT	OPT	OPT	OPT
Trim Tabs	•	•	•	•	•	•	•	•	•	•	•	•
Wind Screen with Stainless Steel Grab Rail	N/A	N/A	•	N/A	•	N/A	•	N/A	•	•	•	•
Walk Thru Transom Door	•	•	•	•	•	•	•	•	•	N/A	N/A	N/A
Windlass w/Anchor Roller Assembly	OPT	•	OPT	OPT	OPT	OPT	OPT	N/A	N/A	N/A	N/A	N/A
CABIN AMENITIES												
Cabin Butane Stove / Sink / Freshwater / Table	N/A	N/A	N/A	•	N/A	OPT	N/A	•	N/A	N/A	N/A	N/A
AC/DC Frig / Microwave / Shore Power	N/A	•	N/A	OPT	N/A	OPT	N/A	N/A	N/A	N/A	N/A	N/A
Cook Top Electric Eye	N/A	•	N/A	N/A	N/A	N/A	N/A	N/A	N/A	N/A	N/A	N/A
Air Conditioner / Shore Power	N/A	OPT	N/A	OPT	N/A	OPT	N/A	N/A	N/A	N/A	N/A	N/A
Hot Water Heater / Shore Power	N/A	•	N/A	OPT	N/A	OPT	N/A	N/A	N/A	N/A	N/A	N/A
Generator Power / Shore Power	N/A	OPT	N/A	OPT	N/A	N/A	N/A	N/A	N/A	N/A	N/A	N/A
Cabin Dinette Table	N/A	N/A	N/A	•	N/A	OPT	N/A	N/A	N/A	N/A	N/A	N/A
Cabin Ice Box	N/A	N/A	N/A	•	N/A	N/A	N/A	•	N/A	N/A	N/A	N/A
Cabin V-Berth Cushions and Filler Cushions	N/A	•	N/A	•	N/A	OPT	N/A	•	N/A	N/A	N/A	N/A
Flip-Up Bunk Bed Option	N/A	•	N/A	•	N/A	OPT	N/A	•	N/A	N/A	N/A	N/A
Mid-Ship Berth Bed & Storage	N/A	•	N/A	N/A	N/A	N/A	N/A	N/A	N/A	N/A	N/A	N/A

Optional Packages

320CC: CRUISE PACKAGE: Bow Cushions, Stereo with 4 Speakers and Satellite Upgrade

320 Express: OVER NIGHT PACKAGE: Generator and Air Conditioner **PILOT HOUSE PACKAGE:** Hard Top with Hard Frame Windshield and Back Drop Curtains

290CC: PRO FISHING PACKAGE: Tilt Steering, Colored Hull, SST Rub Rail and Trim Tab Indicator Switch **COMFORT PACKAGE:** Rear Jump Seats, Bow Cushions, Netting Package **OFFSHORE TOURNAMENT PACKAGE:** SST Cup Holders, Flush Mount Cleats & Bow Light, 4 Additional Rod Holders and Deluxe T-Top **OFFSHORE TOURNAMENT PACKAGE II:** SST Cup Holders, Flush Mount Cleats & Bow Light, 4 Additional Rod Holders and Deluxe Hard Top

270WAC: POWER PACKAGE: Shore Power Hook-up, Built-In Battery Charger, Refrigerator and Microwave **CRUISE PACKAGE:** Passenger Side Lounge Seating, Bait Station Cushion Set, Cockpit Carpet and Rear Jump Seats **TOURNAMENT PACKAGE:** Hard Top with Built-In Radio Box, Grand Slam Outriggers with 15' Poles and Trim Tab Indicator Switch **PILOT HOUSE PACKAGE:** Hard Top with Hard Frame Windshield, Windshield Wipers and Back Drop Curtains

270CC: PRO FISHING PACKAGE: Tilt Steering, Colored Hull, SST Rub Rail and Trim Tab Indicator Switch **COMFORT PACKAGE:** Rear Jump Seats, Bow Cushions and Vanity Storage **OFFSHORE TOURNAMENT PACKAGE:** Knife and Tool Holder, SST Cup Holders, Flush Mount Cleats & Bow Light, 4 Additional Rod Holders and Deluxe T-Top **OFFSHORE TOURNAMENT PACKAGE II:** Knife and Tool Holder, SST Cup Holders, Flush Mount Cleats & Bow Light, 4 Additional Rod Holders and Deluxe Hard Top

240WAC: PRO FISHING PACKAGE: Tilt Steering, Colored Hull, SST Rub Rail and Trim Tabs with Indicator Switch **CRUISE PACKAGE:** Rear Jump Seats, Stereo with 4 Speakers, Cabin Table with Cushion **OFFSHORE TOURNAMENT PACKAGE:** Hard Top with Built-In Radio Box, Flush Mounted Cleats and 4 Additional Rod Holders **DOCKSIDE PACKAGE:** Shore Power, Hot Water on Demand, Refrigerator and Microwave **PILOT HOUSE PACKAGE:** Hard Top with Hard Frame Windshield, Windshield Wipers, Back Drop Curtains and Wind Defroster

240CC: PRO FISHING PACKAGE: Tilt Steering, Colored Hull, SST Rub Rail and Trim Tabs with Indicator Switch **COMFORT PACKAGE:** Rear Jump Seats, Bow Cushions and Vanity Storage **OFFSHORE TOURNAMENT PACKAGE:** Knife and Tool Holder, SST Cup Holders, Flush Mount Cleats & Bow Light, 4 Additional Rod Holders and Deluxe T-Top

220WAC: PRO FISHING PACKAGE: Colored Hull, SST Rub Rail and Rear Jump Seats **OFFSHORE TOURNAMENT PACKAGE:** Flush Mounted Cleats, 3 Additional Rod Holders and Hard Top with Built-In Radio Box

220CC: PRO FISHING PACKAGE: Colored Hull, SST Rub Rail, Trim Tabs and Rear Jump Seats **COMFORT PACKAGE:** Bow Cushion, Tilt Steering, Fresh Water and Cargo Netting Package **OFFSHORE TOURNAMENT PACKAGE:** Flush Mounted Cleats, Flush Mounted Bow Light, 3 Additional Rod Holders and Deluxe T-Top

208CC: SPORT PACK: Bimini Top and Depth and Fish Finder Unit **OFFSHORE TOURNAMENT PACKAGE:** Deluxe T-Top, Leaning Post and Colored Hull

2100 Bay Boat: SPORT PACK: Trolling Motor Panel, 2 Additional Rod Holders, Compass, Rear Jump Seat Cushions **PRO FISH PACK:** Includes Sport Pack, SST Cooler or Leaning Post Seat, Colored Hull, SST Rub Rail, Flush Mounted Cleats, Front Jump Seat Cushions and Extra Rear Livewell **INSHORE TOURNAMENT PACK:** Trolling Motor, Casting Deck Fishing Seat and Console Livewell Upgrade

1900 Bay Boat: SPORT PACK: Trolling Motor Panel, 2 Additional Rod Holders, Compass, Rear Jump Seat Cushions **PRO FISH PACK:** Includes Sport Pack, Colored Hull, SST Rub Rail, Flush Mounted Cleats, Front Jump Seat Cushions and Extra Rear Livewell **INSHORE TOURNAMENT PACK:** Trolling Motor and Casting Deck Fishing Seat

Optional Seating Arrangements



A Capt. Chairs Standard on 2100BB, 208CC, 220CC, 240CC and 270CC



B Optional AFT Folding Seat for 240CC, 240WAC, 270CC, 270WAC, 290CC, 320CC



C Standard Capt. Chair for 320 Express



D Standard Lounge Seat on 320 Express

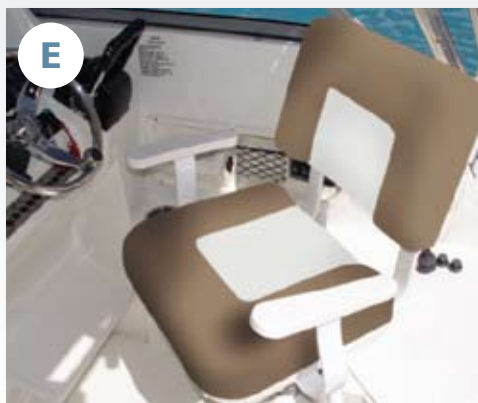

E Standard Capt. Chair on 270WAC

Choose your level of comfort and seating capacity with Sailfish's wide array of seating options – helm seats, leaning posts, front helm seats, lounges and aft seating all designed to deliver the perfect combination of comfort and functionality.



H Standard 220CC Front Helm Seat



I Standard 240CC Front Helm Seat

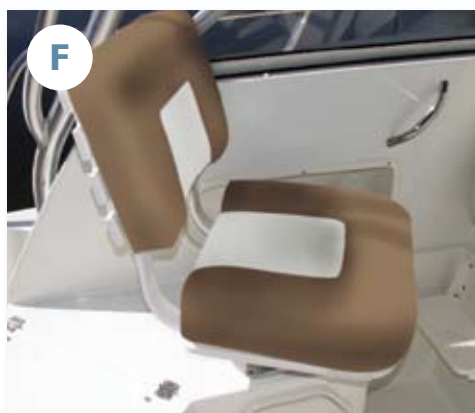

F Standard Passenger Side Capt. Chair on 270WAC



G Optional AFT Seating for 240CC, 240WAC, 270CC, 270WAC, 290CC



J Standard Front Cooler Seat for 270CC, 290CC and 320CC



Optional Deluxe Capt. Chairs and Tackle Storage for 270CC, 290CC and 320CC



Optional Leaning Post with 35 Gallon Livewell and Optional Tackle Storage for 270CC, (Standard on 290CC & 320CC)



220WAC Leaning Post with Cooler



Optional Leaning Post for 1900BB



Optional Leaning Post for 2100BB, 208CC, 220CC, 240CC and 270CC



Optional Leaning Post for 2100BB, 208CC, 220CC, 240CC and 270CC

Hull Colors



Slate Blue



Deep Blue

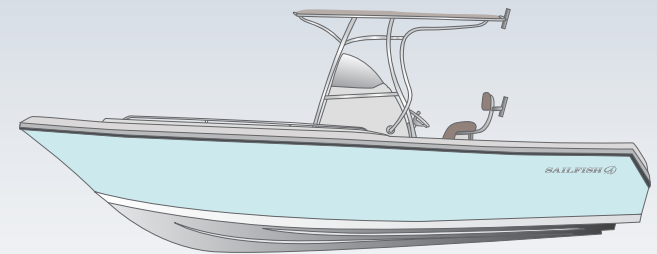

Ice Blue



Bronze



Red



Burgundy



Black



White Standard

Make your Sailfish your own with eight exciting color gelcoats to choose from, each masterfully applied and polished to the brightest possible shine. Solid color or two-tone gelcoat hulls are available.

SAITRISH[®]





Scan to Visit
Our Website!

SAILFISH

Manufactured by

SEMINOLE MARINE GROUP

2501 Industrial Park Drive • Cairo, GA 39828 • 229.377.2125

www.Sailfishboats.com

Seminole Marine, Inc. reserves the right to discontinue models or change prices, specifications, materials, equipment, color or design at any time without incurring obligation. Weight and dimensions of all models are approximate and may vary. Options are subject to change. Photographs in this catalog were shot under supervised conditions with professional models and drivers and boats shown may contain optional equipment.